

Description

The 107DDV2*-G1 24V DC AdaptaBeacon DC Strobe signaling appliances are heavy duty diode-polarized strobe lights intended for use in general utility signaling (non-fire alarm) applications requiring electrical supervision of signaling circuit field wiring. They are available in pendant, bracket, or ceiling mount configurations. These devices are UL and cUL Listed for use in Class I, Division 2, Group A, B, C and D hazardous locations; pendant-mount versions with clear globes are also listed for use in Class II, Division 1, Group E, F and G, Class II, Division 2, Group F and G, and Class III, Division 1 and 2 hazardous locations. Operating Temperature Codes are per the following chart.

Temperature Codes

NOTE: Class II and Class III Listings only apply to Pendant Mount with clear globes

Ambient Temp.	Class I, Div. 2 Groups A, B, C, D	Class II, Div. 2 Groups F, G Class III, Div. 2
		Class II, Div. 1, Groups E, F, G Class III, Div. 1
40°C	300°C (T2)	120°C (T4A)
55°C	450°C (T1)	135°C (T4)
65°C	450°C (T1)	160°C (T3C)

They are UL and cUL listed as Type 3R and 4 enclosures. The series 107DDV2*-G1 strobe flashes a 360-degree beam of light approximately 65 times per minute.

Installation

⚠ WARNING

To reduce the risk of ignition of hazardous atmospheres and shock, do not apply power to the unit until installation has been completed and unit is tightly assembled and secured.

Install this unit in accordance with the applicable requirements in the latest edition of the National Electrical Code or Canadian Electrical Code, using supply wire rated per Table 2.

- Pendant Mount Models** (Figure 1): Install explosion-proof hanger box (not supplied). Pull the unit's wire leads through the 3/4" (19 mm) NPT threaded conduit (not supplied). Secure the 3/4" (19 mm) threaded conduit to the mounting hood.

Ground the unit in accordance with National Electrical Code (NFPA 70) and local requirements.

Wire in accordance with Figure 4.

Secure the 3/4" (19 mm) threaded conduit to the outlet box.

- Bracket Mount Models** (Figure 2): Remove the outlet box from the end of the mounting bracket. Install the outlet box using appropriate hardware (not supplied) for the mounting surface. Pull the field wiring through the outlet box.

Ground the unit in accordance with National Electrical Code (NFPA 70) and local requirements.

Wire in accordance with Figure 4.

Mount the wall bracket back onto the outlet box.

- Ceiling Mount Installation (Figures 3 and 5):** Unscrew and remove the clear outer globe. Remove the two screws holding the circuit assembly to the bottom of the fixture. To separate the ceiling junction box from the fixture housing, remove the remaining two screws at the bottom of the fixture.

Mount the ceiling junction box using appropriate hardware. Pull power source wiring through the ceiling junction box.

Ground the unit in accordance with National Electrical Code (NFPA 70) and local requirements.

Wire in accordance with Figure 4.

Secure the fixture housing on the junction box by replacing the two screws removed above. Reinstall the circuit assembly to the bottom of the fixture using the two screws removed above.

Screw the clear outer globe back on the fixture housing.

- Where applicable, install the optional guard assembly over the clear outer globe and secure using three screws (provided).

⚠ WARNING

To reduce the risk of ignition of hazardous atmospheres and shock, keep assembly tightly closed when circuits are energized.

- Apply power to the unit and ensure proper function.

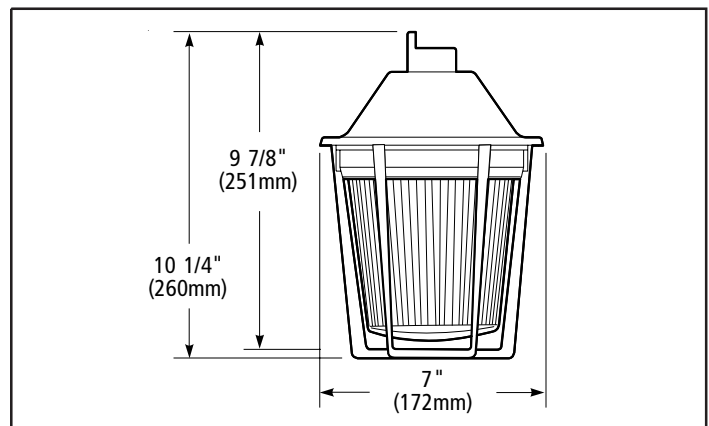

Figure 1. Detail of Pendant Mounting

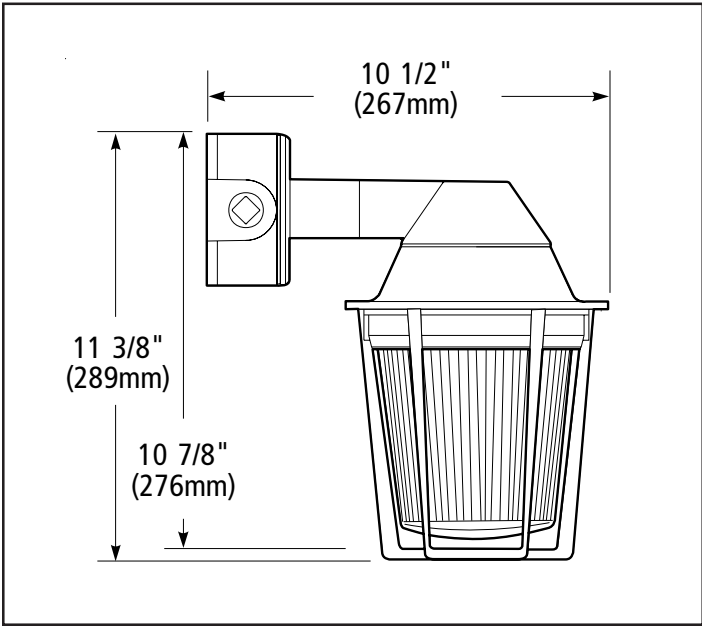

Figure 2. Detail of Bracket Mounting

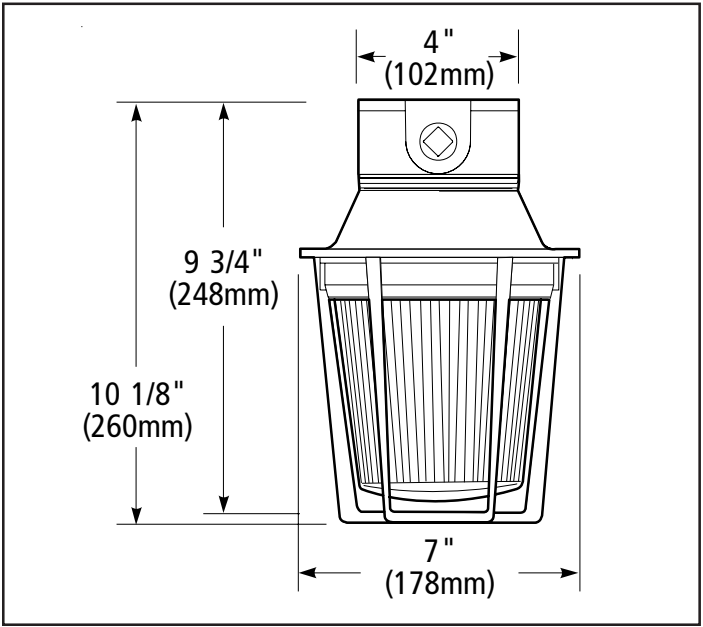

Figure 3. Detail of Ceiling Mounting

Maintenance

⚠ WARNING

To reduce the risk of ignition of hazardous atmospheres and shock, keep assembly tightly closed when circuits are energized.

To reduce the risk of ignition of hazardous atmospheres and shock, disconnect from the supply and circuit and allow five (5) minutes for stored energy to dissipate before disassembling the unit.

2. Unscrew and remove the clear outer globe.
3. To replace the strobe tube, remove the inner lens and replace the appropriate tube as listed in Table 1.
4. Reinstall the inner lens. Screw the clear outer globe back onto the fixture housing.
5. Where applicable, install the guard assembly over the clear outer globe by rotating clockwise until it snaps into place.

Disassemble the unit as follows (Figure 4):

1. Where applicable, remove the guard by rotating counterclockwise.

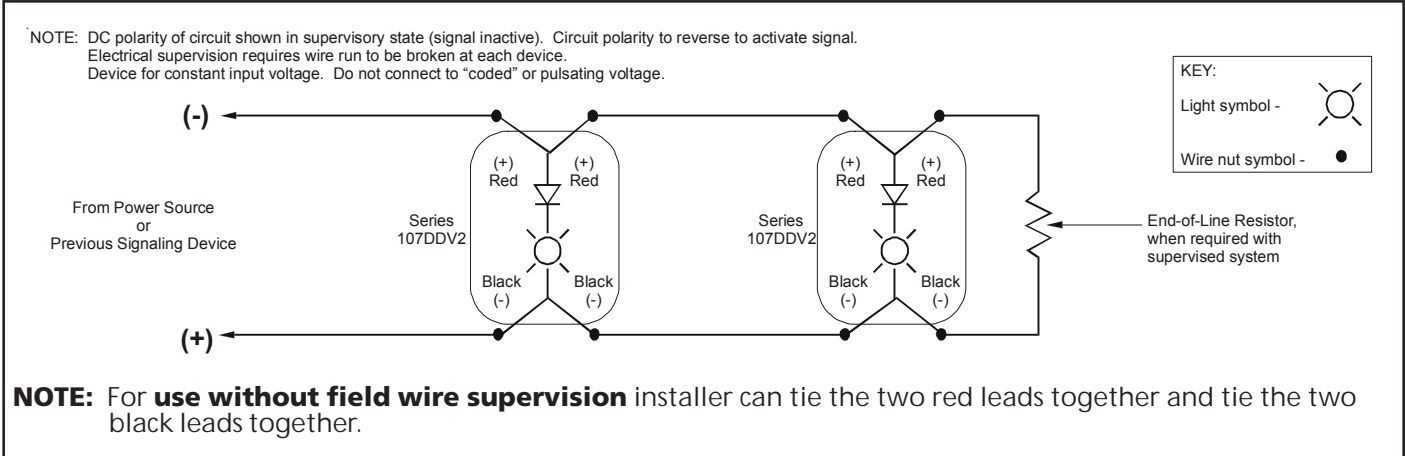

Figure 4. Wiring Diagram

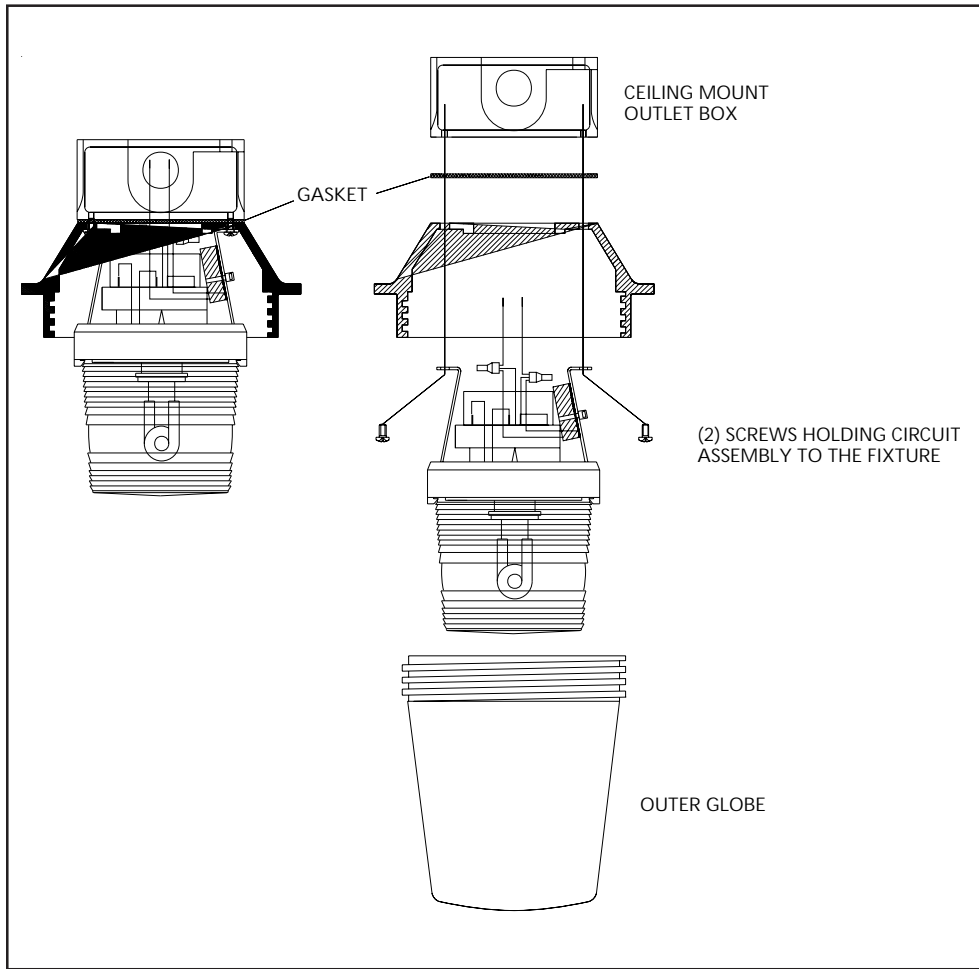

Figure 5. Disassembly of the 107DDV2 Series AdaptaBeacons

Table 1. 107DDV2*-G1 Series AdaptaBeacon Strobes

Catalog Number	Mounting Method	Voltage	Current	Conduit Size	Flash Rate	Strobe Tube Replacement
107DDV2PST*-G1	Pendant	24V DC	1.4A	3/4" NPT	Approx. 65 fpm	92-ST
107DDV2BST*-G1	Bracket					
107DDV2CST*-G1	Ceiling					

*Letter in this position denotes color of the globe: A - amber, B - blue, C - clear, G - green, R - red or M - magenta

Table 2. Supply Wire Temperature Markings

Ambient Temperature	Supply Wire Temperature Marking
40°C	60°C
55°C	75°C
65°C	90°C